

# Eclipse Ratiomatic Burners

*Model 1500 RM  
For Serial Numbers 95-5500 & Above*

Version 1

Parameter	Specification	
<b>Input vs. Chamber Pressure</b>	17,700,000 BTU/hr @ -5.0" w.c.	5188 kW @ -12.5 mbar
	16,700,000 BTU/hr @ -3.0" w.c.	4895 kW @ -7.5 mbar
	15,600,000 BTU/hr @ -1.0" w.c.	4572 kW @ -2.5 mbar
	15,000,000 BTU/hr @ 0.0" w.c.	4397 kW @ 0.0 mbar
	14,400,000 BTU/hr @ +1.0" w.c.	4221 kW @ +2.5 mbar
	13,700,000 BTU/hr @ +2.0" w.c.	4015 kW @ +5.0 mbar
	Input may be increased by 20% if sufficient secondary air is available to complete combustion.	
<b>Minimum Input</b>	150,000 BTU/hr (44 kW) with neutral chamber. Will be slightly higher with negative chamber pressure.	
<b>Turndown</b>	100:1 with neutral chamber pressure	
<b>Configurations</b>	<b>Burner Configuration</b>	<b>Maximum Chamber Temperature</b>
	Burner with alloy tube	1500°F (816°C)
	Burner with refractory block	1800°F (982°C)
Maximums shown are for average installations. Depending on conditions, higher temperatures can be obtained. Contact Eclipse for details.		
<b>Fuel</b>	Standard nozzle burns natural gas, propane, propane/air mixes without changing internals. Contact Eclipse for other fuels.	
<b>Gas Inlet Pressure at the proportionator inlet</b>	Minimum: 22" w.c. (55 mbar) natural gas, .65 s.g. Maximum: 2 psig (138 mbar) natural gas, .65 s.g.	
<b>Pilot Gas Pressure at the pilot cock inlet</b>	Minimum: 6" w.c. (15 mbar) natural gas, .65 s.g.	
<b>High Fire Flame Length</b>	144" (3.66 m) Measured from the end of the firing tube, firing parallel to air flow with neutral chamber pressure. When firing perpendicular to air flow, flame length will be shorter. Contact Eclipse for details.	
<b>Piloting</b>	Integral spark-ignited pilot; ignition plug included	
<b>Flame Monitoring</b>	By UV scanner only. Scanners & mounting kits are available from Eclipse.	
<b>Control Motor Requirements</b>	90° travel with full stroke timing of 15 seconds or longer. Ovens with high chamber drafts or backpressures may require less than a full 90° stroke. In these cases, use adjustable stroke motors or motors equipped with travelling limiting auxiliary switches.	
<b>Emissions</b>	Ratiomatics produce low NO <sub>x</sub> , CO and aldehydes. Emissions performance depends not only on the burner, but also factors such as chamber temperature, chamber design, and heat loading. For estimates of Ratiomatic performance in your application, call Eclipse.	
<b>Packaging Options</b>	IRI or NFPA type valve trains, and UL recognized valve packages available.	

**CAUTION:**  
It is dangerous to use any fuel burning equipment unless it is equipped with suitable flame sensing devices and automatic fuel shut-off valves. Eclipse can supply such equipment or information on alternate sources.

## Dimensions

Dimensions are subject to change without notice. Contact Eclipse for certified prints prior to fabrication or installation.

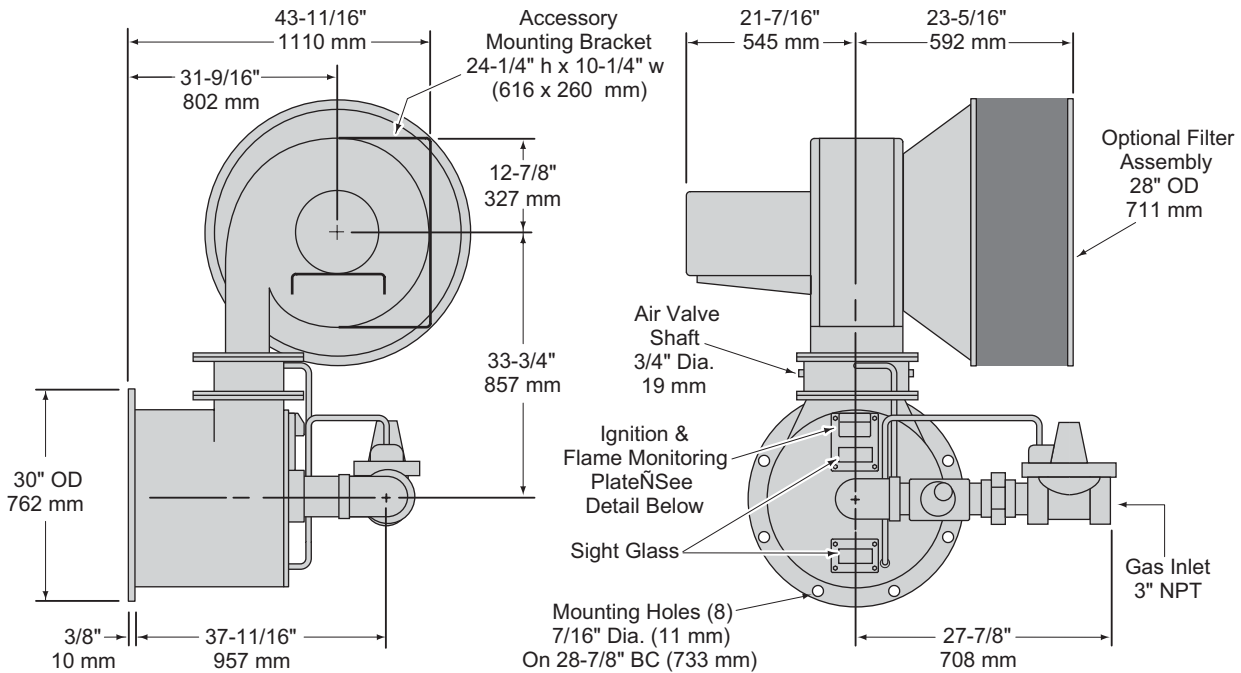

### Alloy Tube Assembly – #110281

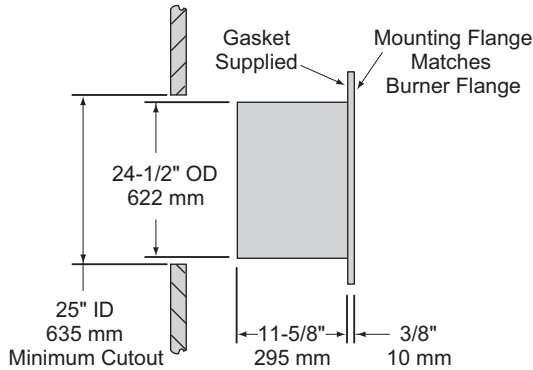

### Block & Holder Assembly – #187297-61

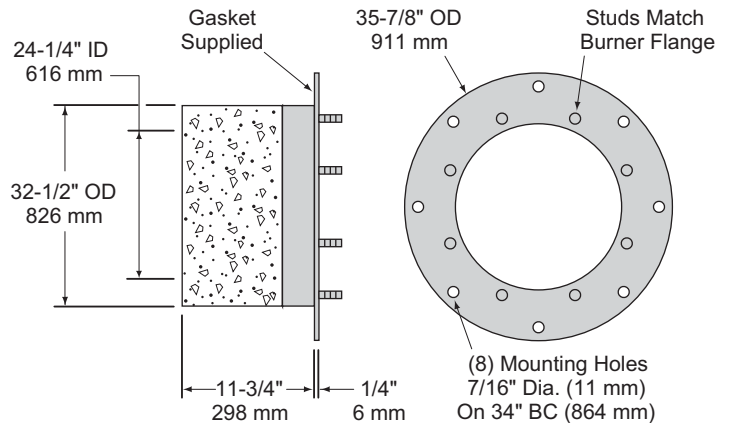

Item	Description	Part No.
1500 RM Burner Assembly	w/Alloy Tube; Left Hand Blower (shown)	110413
	w/Alloy Tube; Right Hand Blower (motor opposite side)	110403
	w/Block & Holder; Left Hand Blower (shown)	110443
	w/Block & Holder; Right Hand Blower (motor opposite side)	110433
Air Filter Assembly	Optional	110287
Replacement Filter Element	-	15608 & 10411
Spark Plug <sup>1</sup>	For burner with tube or block	150000-12
Blower Motor <sup>1</sup>	15 hp, 230/460/3/60 TEFC, 3600 RPM	15545
Proportionator <sup>1</sup>	Eclipse ES 369, 3"	10316
Pilot Cock <sup>1</sup>	Eclipse lever handle, 1/4"	12659
Gas Adjusting Butterfly <sup>1</sup>	Eclipse 112 BV, 3"	500993

<sup>1</sup> Included with burner assembly.

**Block & Holder and Alloy Tubes are interchangeable in the field.**

### Flame Monitoring Plate Detail

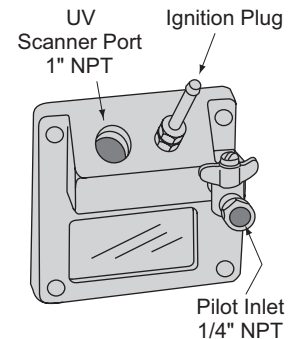

**ECLIPSE**<sup>®</sup>  
Innovative Thermal Solutions



**Offered By:**

Power Equipment Company  
2011 Williamsburg Road  
Richmond, Virginia 23231  
Phone (804) 236-3800  
Fax (804) 236-3882

---

[www.peconet.com](http://www.peconet.com)